

OKEECHOBEE BOULEVARD M.U.P.D.

BEING A REPLAT OF PARCELS 4 AND W-2, GOLDEN LAKES OFFICE PARK & GOLDEN LAKES PLAZA, AS RECORDED IN PLAT BOOK 34, PAGES 178-180, PALM BEACH COUNTY PUBLIC RECORDS, LOCATED IN SECTION 28, TOWNSHIP 43 SOUTH, RANGE 42 EAST, PALM BEACH COUNTY, FLORIDA
FEBRUARY, 2002 SHEET 2 OF 3

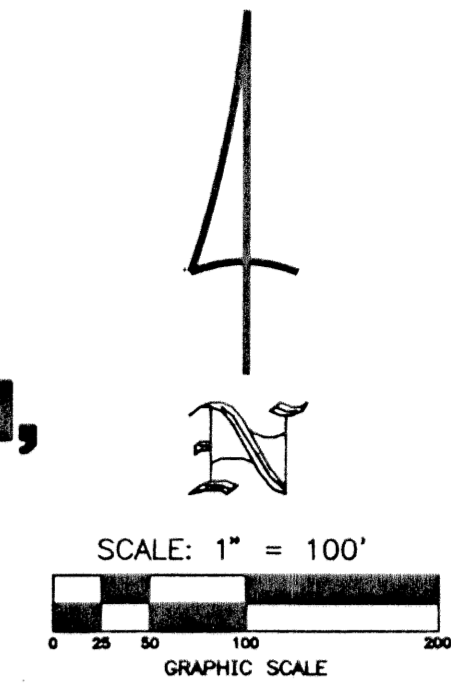

COUNTY OF PALM BEACH
STATE OF FLORIDA
THIS PLAT WAS FILED FOR RECORD
AT _____ M. THIS _____ DAY
OF _____, 2002 AND JULY
RECORDED IN PLAT BOOK NO. _____
ON PAGE _____
DOROTHY H. WILKEN,
Clerk Circuit Court
By: _____ D.C.

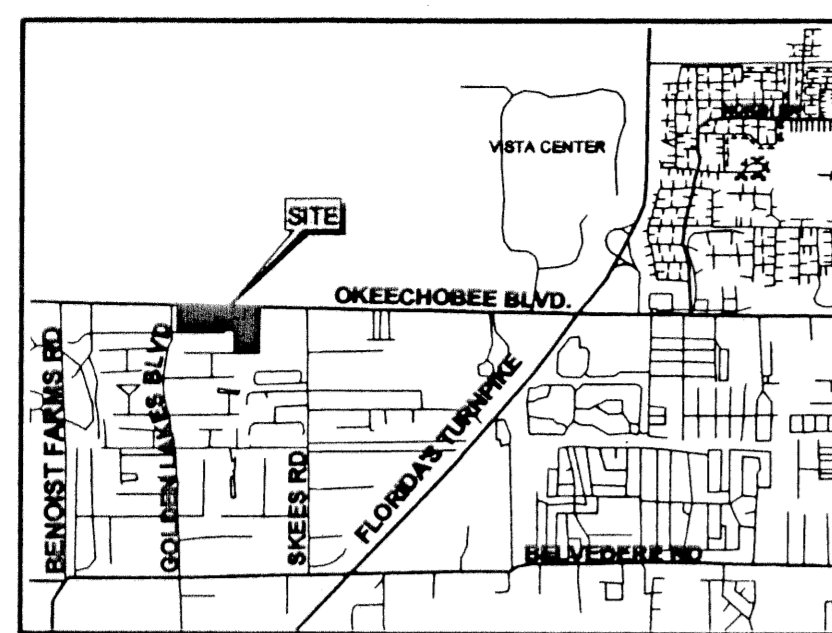
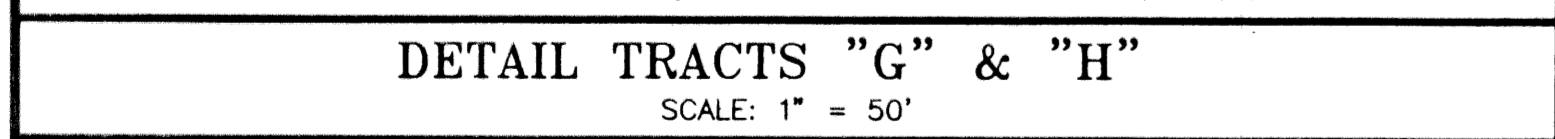
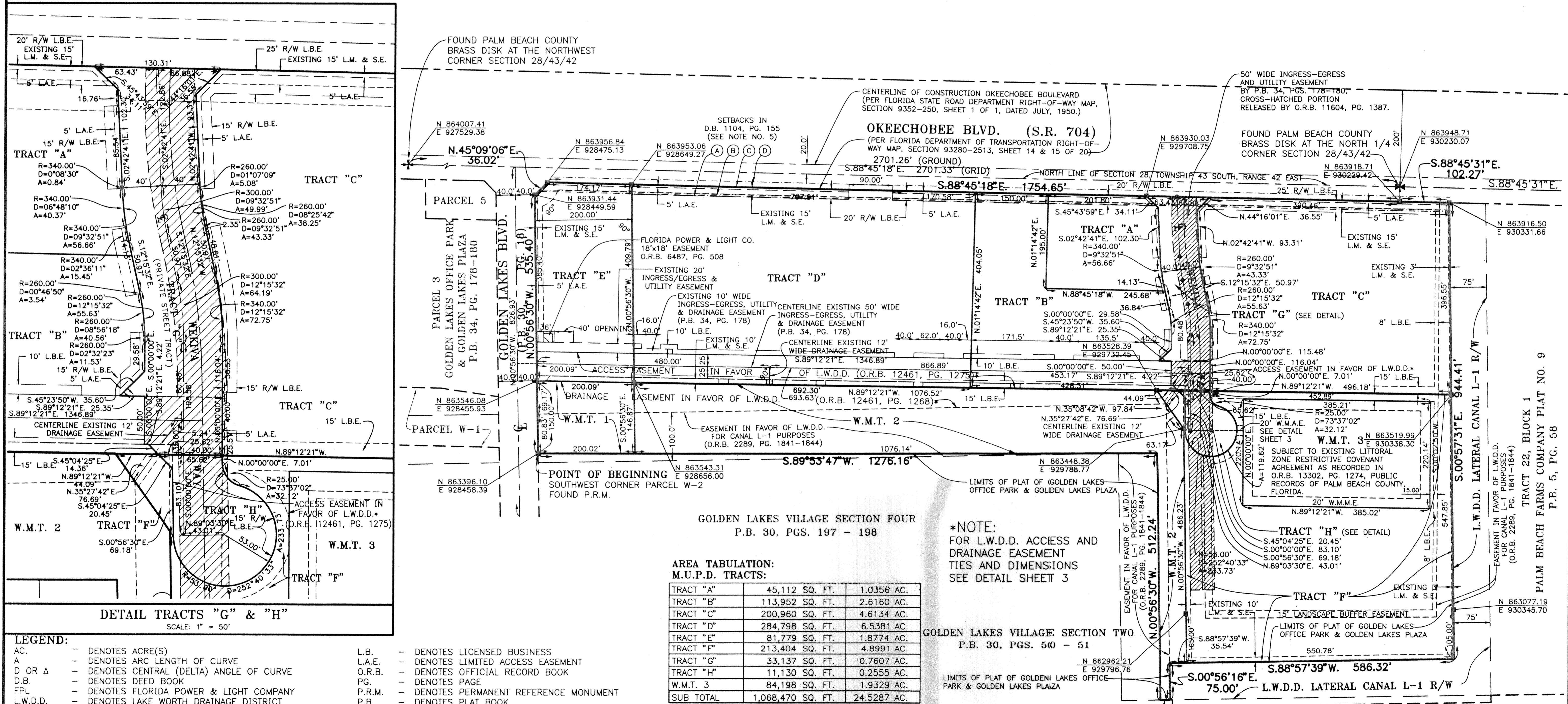

LEGEND:
AC. - DENOTES ACRE(S)
A - DENOTES ARC LENGTH OF CURVE
D OR Δ - DENOTES CENTRAL (DELTA) ANGLE OF CURVE
D.B. - DENOTES DEED BOOK
FPL - DENOTES FLORIDA POWER & LIGHT COMPANY
L.W.D.D. - DENOTES LAKE WORTH DRAINAGE DISTRICT
L.B.E. - DENOTES LANDSCAPE BUFFER EASEMENT
L.M. & S.E. - DENOTES LANDSCAPE MAINTENANCE & SIGN EASEMENT
L.B. - DENOTES LICENSED BUSINESS
L.A.E. - DENOTES LIMITED ACCESS EASEMENT
O.R.B. - DENOTES OFFICIAL RECORD BOOK
PG. - DENOTES PAGE
P.R.M. - DENOTES PERMANENT REFERENCE MONUMENT
P.B. - DENOTES PLAT BOOK
R - DENOTES RADIUS OF CURVE
RGE. - DENOTES RANGE
R/W - DENOTES RIGHT-OF-WAY
SEC. - DENOTES SECTION
SQ. FT. - DENOTES SQUARE FOOT (FEET)
S.R. - DENOTES STATE ROAD
TWP. - DENOTES TOWNSHIP
W.M.A.E. - DENOTES WATER MANAGEMENT ACCESS EASEMENT
W.M.M.E. - DENOTES WATER MANAGEMENT MAINTENANCE EASEMENT
W.M.T. - DENOTES WATER MANAGEMENT TRACT

THIS INSTRUMENT WAS PREPARED BY: WAYNE LARRY FISH IN THE OFFICES OF
W.L.FISH & COMPANY
PROFESSIONAL SURVEYORS AND MAPPERS
105 S. Narcissus Ave., Suite 712, West Palm Beach, Florida 33401
Phone: (561)833-5001 L.B. 6216 Fax: (561)659-6745
E-mail: mappers@wlfish.com

**AREA TABULATION:
M.U.P.D. TRACTS:**

TRACT	SQ. FT.	AC.
TRACT "A"	45,112	1.0356
TRACT "B"	113,952	2.6160
TRACT "C"	200,960	4.6134
TRACT "D"	284,798	6.5381
TRACT "E"	81,779	1.8774
TRACT "F"	213,404	4.8991
TRACT "G"	33,137	0.7607
TRACT "H"	11,130	0.2555
W.M.T. 3	84,198	1.9329
SUB TOTAL	1,068,470	24.5287

NON-M.U.P.D. TRACTS:

TRACT	SQ. FT.	AC.
W.M.T. 1	29,687	0.6815
W.M.T. 2	179,387	4.1182
SUB TOTAL	209,074	4.7997
TOTAL PLAT	1,277,544	29.3284

*NOTE:
FOR L.W.D.D. ACCESS AND DRAINAGE EASEMENT TIES AND DIMENSIONS SEE DETAIL SHEET 3

GOLDEN LAKES VILLAGE SECTION TWO
P.B. 30, PGS. 50 - 51
LIMITS OF PLAT OF GOLDEN LAKES OFFICE PARK & GOLDEN LAKES PLAZA

HIGH SIERRA SUBDIVISION
P.B. 36, PG. 45

SUBDIVISION Okeechobee Blvd M.U.P.D.
BOOK 94 PAGE 194
FLOOD ZONE 5
QUAD # 40
SE
TAZ # 81D
PUD NAME